



## Ifor Williams Trailers Ltd.

[www.iwt.no](http://www.iwt.no)

Serial No:

---

# USER'S HANDBOOK

These instructions are provided to help you to get the best possible service from your trailer. To ensure that the trailer is used safely, we strongly recommend that the instructions are read by all users and all the recommendations followed.

***Misuse may invalidate warranty***

---

### Important

**If you sell your trailer, please pass this book on to the new owner.**

---



- Read this manual carefully before operating this trailer for the first time, ensure that all instructions are followed and any safety advice adhered to.
- Not following the instructions and advice can damage your trailer or injure yourself or others.
- Not following the instructions and advice can invalidate your guarantee.
- Ensure this manual is kept in a safe place and referred to when needed during the life of this trailer.
- The best place to store this manual is in a suitable location within the towing vehicle.
- The manual includes a section to record the service information and as such is an integral part of the product supplied to you.
- If you rent or sell the trailer, then pass on this and any other relevant documentation to the new owner/operator.



- As well as the instructions and safety advice in this manual, you must observe all national regulations that relate to driving a vehicle and trailer, if you are a commercial user then observe all laws, rules, licencing and regulatory requirements that pertain to your operational obligations.
- Be aware that all countries will be different, it is your responsibility to ensure that you comply with local laws and rules.
- For example, certain countries will require you to maintain your trailer and have a major periodic technical inspection.

Errors excepted.

The Manufacturer:

## **Ifor Williams Trailers Ltd.**

Reserves the right to make technical changes to the design, equipment and accessories with respect to the information and illustrations within this manual.

### **Obligations of the operator**



The trailer may only be operated in perfect condition.

Ensure that this manual is included with the trailer, for example if it is sold.

Only utilise trained or instructed personnel.

Ensure that this manual is complied with during all life cycle phases of the trailer.

Provide the requisite operating and auxiliary materials.

### **User Group**

The trailer should only be operated by users who possess the required skills, experience and knowledge relevant to the trailer model and who meet the qualifications detailed in section 1.6.1

## 1.1 Introduction

Please take the time to read the contents of this manual before you attach the trailer to the towing vehicle, or attempt to load it. It is a good idea when reading this manual, to take a tour of the trailer with all persons who will be using it.

Make sure everyone responsible is fully conversant with the procedures for attaching to the towing vehicle, towing, loading and maintaining the unit. By following, understanding and practising the information and procedures in this manual, the trailer will give you many miles/kilometres of safe travelling.

Certain information in this manual is governed by law and is subject to change without prior notice.

Great care has been taken to ensure that the information is correct at the time of publication. However, it is the trailers user's sole responsibility to ensure that they fully comply with all legal requirements.

We reserve the right to implement changes and improve specifications without prior notice.

*Whilst every effort has been made to ensure the accuracy of these instructions, they are intended only as a guide to the user.*

## 1.2 Customer Care

If you require any help or advice, please do not hesitate to contact our customer care team:

**email [post@iwt.no](mailto:post@iwt.no) or  
Telephone +47 623 44 141**

## 1.3 Accompanying Literature

Various publications and appliance instruction manuals are supplied with your user handbook. These are to be read in conjunction with the user manual.

### **“Towing and the Law” –SMMT Booklet Included with this handbook**

Compiled by The Society of Motor Manufactures and Trailers Ltd. There are wide-ranging rules and regulations to comply with when towing a trailer. This book covers subjects such as the suitability of a vehicle for towing a particular trailer and the necessity for correct maintenance of tyres and brakes. “Towing and the Law” has been designed to assist trailer users to ensure that they are complying with the law.

Please note that the information given in “towing and the Law” is subject to change without prior notice. Great care has been taken to ensure that the information is correct at the time of publication. However, it is the owner/ user’s sole responsibility to ensure that they fully comply with all legal requirements. Ifor Williams Trailer Ltd. Will not accept liability for any inaccuracy or incorrectly stated legal requirements.

## 1.4 Security

Your trailer is security marked but as an added means of assisting the police in making a positive identification we recommend that you mark the trailer with your postcode or another unique mark. IWT Horsebox trailers are also fitted with Datatag electronic tags for use with Police scanner systems.

If you wish to protect your trailer with a coupling lock or other security device your distributor will be pleased to advise you of the various devices which are available.

The trailer is supplied with two keys, one for the coupling hitch and one for the entrance door.

## **1.5 Warranty**

Your new Ifor Williams trailer is warranted against defects in material and workmanship. The trailer is not designed to be water-tight.

### **1.5.1 Warranty Claims**

Warranty claims should first be directed to the distributor, who will in many cases be able to rectify the fault quickly on their premises, or assist in presenting the problem to IWT for appraisal.

## 1.6 Safety



THE FOLLOWING POINTS ARE MOST IMPORTANT TO ENSURE SAFE USE OF THE TRAILER

- Ensure the trailer is serviced and maintained to the manufacturer's recommendations.
- Always take care when entering and exiting the trailer.
- Never attempt to lift the tow hitch with your hands when hitching the trailer to the tow vehicle or at any other time. Always wind the jockey handle to raise and lower the hitch.
- Use an approved towing bracket and coupling ball/jaw on the towing vehicle.
- Always follow any recommendations for maximum trailer weights given in your towing vehicle's handbook.
- Never exceed the maximum gross weight shown on the trailer plate.
- Never exceed the recommended towing speeds.
- Check tyre pressures before every journey. Correct pressures are shown on the multifunction sticker.
- Check wheel bolts after first 25 miles of service and subsequently before every journey.
- Check lighting equipment before every journey.
- Always make use of the breakaway cable.
- Always leave the handbrake on or chock the wheels when the trailer is parked. When parking the trailer for extended periods, it is advisable to chock the wheels and release the handbrake to avoid the possibility of the brake shoes adhering to the brake drum surface.
- With the trailer coupled to the towing vehicle, the bed of the trailer should be level
- Never exceed the maximum nose weight.
- A nose weight that is too light can cause stability issues.
- Except in emergencies, never unhitch a loaded trailer. If absolutely unavoidable, take great care to ensure that the jockey wheel is securely clamped and the handbrake is fully applied. If the trailer is on a slope, chock the wheels as an added precaution.
- Always tie down securely or restrain effectively all loads and carry out regular checks on the condition of the load during the journey.
- Ensure all ramps, doors, hatches, etc. are secure before towing the trailer.

If any additional equipment is to be fitted to the trailer that involves any welding, drilling or any structural modifications to the trailer, then this is done entirely at the owner's risk and may invalidate your warranty. Always seek professional advice and guidance from your coach builder/bodywork specialist before undertaking any modifications

## 1.6.1 Use

### **Qualification of the personnel**

Ifor Williams Trailers Ltd. Products may only be used and maintained by personnel who are aware of:

- This manual
- The trailer and associated towing vehicle
- The operating and maintenance instructions of the suppliers
- The local legislation and laws pertaining to road use and licensing
- All health and safety/accident prevention regulations as well as other safety, occupational health and road traffic regulations
- Knowledge about transporting animals if relevant
- Knowledge about the Animal welfare legislation if relevant

### **Reasonably foreseeable misuse**

Any use extending beyond the prescribed transport applications is regarded as other than intended.

In particular, this includes:

#### **General**

- Non-observance of the safety instructions within this manual
- Transport of persons
- Transport of animals too small, or too large for the intended purpose.
- Driving with insufficient load securing
- Driving with unlocked flaps/doors if relevant
- Driving with the Breast/Breeching bars unsecured or not inserted if relevant
- Irregular cleaning of the cargo bed/internal space
- Exceeding the drawbar load and trailer load
- Transport of other loads – without load securing

## **The Manufacturer:**

### **Ifor Williams Trailers Ltd.**

Rejects any liability for damage which arises through the disregard of this manual – the risks are borne solely by the user.

## **Disclaimer**

Any liability of the manufacturer becomes null and void if:

- The trailer and its components are altered without authorisation
- The original parts or conversion parts/accessories approved by Ifor Williams Trailers Ltd. are replaced by other components
- Retrospective changes have been made to the trailer (e.g. new drill holes in the frame or the re-boring of existing drill holes in the frame). This is considered by Ifor Williams Trailers Ltd. to be a structural change and the type approval then becomes invalid.
- Non-approved accessories or third-party spare/component parts which are not original Ifor Williams Ltd. parts are attached or installed. The type approval of the trailer, possibly even the insurance cover, becomes null and void.
- Care and maintenance intervals prescribed by the manufacturer are not complied with.

Any risks and liability exclusions resulting from this also exist if:

- Acceptance inspections have been carried out by inspectors/authorised experts of the technical inspection authorities or officially recognised organisations.
- Official approvals are available.

## **1.6.2 Check before every journey**

### **Sources of danger**

Take note of the following points without fail:

- Coupling and uncoupling a trailer, do not place hands or feet where they can become trapped or crushed.
- Clearance heights on the route.

- Exceeding the maximum permissible gross weight, or one-sided overloading through incorrect loading.
- Poorly secured or unsecured goods and/or body components.
- Reversing – keep an eye on the rear area.
- Excessive twisting whilst manoeuvring.
- Overloading of the trailer, axles & brakes.
- Fitting incorrect wheels and tyre sizes.
- Use of wheels with incorrect off-sets, one-sided run-out or centrifugal imbalance.
- Overstressing as a result of reckless and inappropriate driving or handling.
- Impact and shock stress of the axles.
- Speed inappropriate for the road conditions and the loading status of the trailer, especially in bends.
- The parked trailer can tilt or sink in on soft uneven ground.
- Driving on severe inclines.
- Loading/unloading of the trailer in an area with a steep gradient.
- Failure to clean the cargo bed after every use.
- Driving with opened but unsecured ramps, doors & hatches.

### **Chassis area**

Note the following in general:

- Establish the electrical connections
- Retract the support devices and lock them
- Check the tyres and rims for damage
- Check the tyre pressure, including the spare wheel
- Check the tightening torque of the wheel nuts
- In the case of a new trailer, re-tighten the wheel nuts after 25 miles and after the first journey.
- Secure the spare wheel, wheel chock and any other loose items.
- Check the number plate and signs
- Check that the trailer coupling is in perfect condition

**Body area**

Close and secure all body components, such as:

- Ramps
- Hatches
- Doors
- Load securing equipment
- Fix any load
- Ensure loads are balanced

## 1.7 Glossary of Terms

<b>Trailer</b>	Your new Ifor Williams trailer.
<b>GVW</b>	Gross vehicle weight - Referring to the towing vehicle, this is the maximum allowable weight of the vehicle and its contents.
<b>MGW</b>	Maximum Gross Weight - Referring to the trailer, this is the manufacturers stated maximum for the trailer and its load, often governed by such items as coupling, tyres etc. although this may have been adjusted downward for one of a number of reasons.
<b>MAM</b>	Maximum Authorised Mass, A new term used in driver licensing regulations, this has the same meaning as MGW detailed above.
<b>Unladen weight</b>	The weight of an empty trailer (usually as delivered before fitting of any optional accessories).
<b>Payload</b>	The amount you are allowed to carry, the payload and the unladen weight added together must never exceed the Maximum Gross Weight.
<b>Nose weight/ Imposed Load</b>	The downward force exerted on the tow ball by the drawbar of the trailer.
<b>Left &amp; Right</b>	Are always referred to with regard to forward travel, i.e. viewed from on-board the trailer with the drawbar visible in front of you.
<b>Outfit</b>	The towing vehicle and trailer combined.
<b>Vehicle Combination</b>	The towing vehicle and trailer combined.
<b>VIN</b>	Vehicle Identification Number
<b>GTW/GCW</b>	Gross Train Weight/Gross Combination weight - This is the total weight of the towing vehicle plus trailer plus load.

## 1.8 – Trailer Plating

Your trailer will have identification plates which are typically attached to the right-hand side of the drawbar, along with another plate (or stamping) on the coupling head. The main drawbar plate (the VIN plate) contains important information including the trailers serial number and its max gross weight.

A CE plate will also be fitted if the trailer requires CE marking.

Before towing your Ifor Williams Trailer be sure to check that the vehicle-trailer combination is suitable. Also ensure your driving licence permits you to tow the trailer / load combination.

### 1.8.1 – VIN Plate

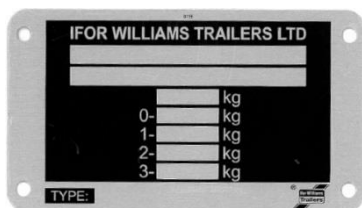

1. EC Approval Number -
2. VIN Number (the last 7 digits are the Ifor Williams serial number)
3. Maximum Gross Weight (MGW)
4. Maximum Permissible static load on the coupling
5. Maximum Permissible Ground load the first axle
6. Maximum Permissible Ground load on the second axle
7. Maximum Permissible Ground load on the third axle
8. IWT internal description

## 1.8.2 – Drawbar Plate

The drawbar plate contains no additional information useful to the typical user. In the particular case of the trailer being towed by a Heavy Goods Vehicle the  $D_c$  value may be required.

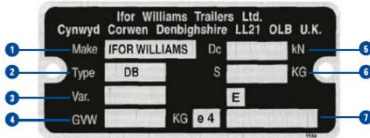

1. Drawbar Manufacturer

2. Internal Description

3. Internal Description

4. Maximum Gross Weight allowed

5. Theoretical Horizontal Reference Force ( $D_c$  value)

6. Maximum static Load

7. Approval number

## 1.8.3 - Coupling plate

This contains mandatory information relating to the approval of the coupling alone. It contains no information useful to the trailer.

## 1.8.4 – CE plate (if relevant)

The CE plate is mounted on the trailer chassis or on the trailer mounted equipment.



1. Manufacturer's name and address
2. Model description
3. Variant
4. Year of manufacture
5. CE mark

## 2 Additional Safety Instructions

### 2.1 Transporting Livestock

When transporting livestock, full use should be made of partitions to ensure that the animals are not thrown about by the motion of the vehicle. This is one of the Welfare of Animals (Transport) (England) 2006 (EC 1/2005) for the protection of animals during transit, but also it is most important for the safe towing of the trailer.

Cross divisions are available for all livestock trailers. They are not provided with the trailer as standard as customers' requirements vary considerably depending on the type of stock to be carried. However, the trailers are provided with receivers as standard to accept the cross divisions at intervals along the trailer.

## Minimum areas per animal type

These figures may vary depending on different conditions, consult the official document for a full explanation.

### Cattle and Calves

- Small Calves (50kg) – 0.30m<sup>2</sup> to 0.40m<sup>2</sup>
- Medium Calves (110kg) – 0.40m<sup>2</sup> to 0.70m<sup>2</sup>
- Heavy Calves (200kg) – 0.70m<sup>2</sup> to 0.95m<sup>2</sup>
- Medium Cattle (325kg) – 0.95m<sup>2</sup> to 1.30m<sup>2</sup>
- Heavy Cattle (550kg) – 1.30m<sup>2</sup> to 1.60m<sup>2</sup>
- Very Heavy Cattle (>700kg) – >1.60m<sup>2</sup>

### Sheep & Goats

- Shorn Sheep & Lambs of 26kg & over - <55kg 0.20m<sup>2</sup> to 0.30m<sup>2</sup>  
- >55kg > 0.30m<sup>2</sup>
- Unshorn Sheep - <55kg 0.30m<sup>2</sup> to 0.40m<sup>2</sup>  
- >55kg > 0.40m<sup>2</sup>
- Heavily Pregnant Ewes - <55kg 0.40m<sup>2</sup> to 0.50m<sup>2</sup>  
- >55kg > 0.50m<sup>2</sup>
- Goats - <35kg 0.20m<sup>2</sup> to 0.30m<sup>2</sup>  
- 35kg to 55kg 0.30m<sup>2</sup> to 0.40m<sup>2</sup>  
- >55kg > 0.40m<sup>2</sup> to 0.75m<sup>2</sup>
- Heavily Pregnant Goats - <55kg 0.40m<sup>2</sup> to 0.50m<sup>2</sup>

- **Pigs** - Must be able to at least lie down and stand up in their natural position

Non-slip floors are standard on all livestock trailers. However, the Order states that new straw bedding (or similar) must be used if calves or pigs are carried.

### **Horses**

Straw or similar bedding should also be used in horsebox trailers to improve comfort and footing when the floor is wet.

**Note:** The above references to the Welfare of Animals (Transport) are not intended to be definitive legal interpretations. If you are in any doubt about the requirements of the Order, advice can be obtained from your local Animal Health Inspector (County Council Trading Standards Department).

## **2.2 Towing Speeds**

All trailers are fitted with wheels, tyres and braking systems that comply with the UK

Construction and Use Regulations. The maximum speed limit under the regulations

is 60mph. However, we strongly recommend that speeds are reduced when transporting livestock or any unevenly distributed load.

**Note:** The 60mph limit is allowed on motorways and unrestricted dual carriageways only. On other unrestricted roads the limit is 50mph.

## **2.3 Transporting livestock in the DP120G trailer**

It is recommended that when transporting livestock in the DP120G, speed should not exceed 25mph.

## 3 – Towing

### 3.1 – Preparation for Safe Towing

THE FOLLOWING POINTS ARE IMPORTANT TO ENSURE SAFE USE OF THE TRAILER

- Ensure the trailer and equipment are serviced and maintained as detailed in this manual.
- Use an approved towing bracket and tow ball on the towing vehicle. Only use tow-bars and tow-balls that are approved by the vehicle manufacturer and that have been fitted by his approved agent. In case of doubt get the installation checked by the vehicle manufacturers Agent.
- Never load the trailer such that the coupling imposed load exceeds the maximum specified in the towing vehicle handbook.
- If the trailer is parked on a slope, chock the wheels as an added precaution.
- Check tyre pressures before every journey. Correct pressures are shown on a label on the trailer. Towing vehicle tyre pressures, especially the rear tyre pressures, are also vitally important. Low pressures not only risk failure but contribute to instability.
- Check wheel bolts after first 25 miles of service and subsequently before every journey. The correct torque is 110 Nm (81 lbf.ft) for 5-stud wheels and 88 Nm (65 lbf.ft) for 4-bolt wheels. Use a torque wrench and do not overtighten. Overtightening deforms the wheel and makes it far more likely the wheel will come loose.
- Ensure all trailer lights work before every journey.

- Note: The reversing light will only work if your towing vehicle electrical socket has been appropriately wired.
- Always connect the coupling safety cable (breakaway cable) to the vehicle tow-bar when towing. Be aware that this has the safety critical function of putting the trailer handbrake on in the event of a trailer breakaway and then break itself. (Its function is not to pull the detached trailer along the road.)
- During extended journeys, carry out regular checks on the trailer.

## **3.2 – Towing Vehicle Compatibility**

Before towing, the first consideration should be whether the towing vehicle is suitable for the trailer. The following factors should be considered before attempting to tow any of the trailers covered by this manual:

### **3.2.1 – Gross Train Weight (GTW)**

The Selected towing vehicle must have a maximum GTW/GCW (consult the towing vehicle VIN plate) which exceeds the trailer MGW plus the actual laden weight of the towing vehicle.

### **3.2.2 – Imposed Load**

- The selected towing vehicle should have a maximum coupling imposed load capacity equal to at least 4% of the trailer MGW.
- In the particular case of maximum gross weight trailers (3.5 tonne) the 4% minimum imposed load therefore equates to 140 kg. It should not be assumed that most vehicles can accept this imposed load. In fact, only a small number of vehicles can accept this level of imposed load.

### **3.2.3 – Coupling Height**

With the trailer coupled to the towing vehicle, the frame of the trailer should be level.

Some leeway is allowed. In general, if the trailer has been loaded so as to give the correct imposed load (see Appendix A), and the height from the ground to the centre of the ball is within the EC standard range of 430 +/-35 mm – i.e. between 395mm and 465mm – it should be safe to tow. However, level or slightly higher at the front is always best and towing brackets with built in adjustment are available for most vehicles if a correction is necessary.

### **3.2.4 – Coupling Type**

- Note that many vans with rear side hinged doors may have clearance issues between the doors and a correctly position hitch. Lowering the coupling below the EC minimum (395mm laden ground to centre of ball) is not a safe solution.
- The standard and preferred coupling is 50mm ball type. These will comply with Directive 94/20/EC, ECE R55. UK trailers can be supplied with “eye” couplings which are not covered by the above standard and can therefore be mounted below the EC height limits. Eye couplings are the most frequently used method of getting around the “van door” problem mentioned above. These are only recommended for fleet usage where there is programmed maintenance or for use with farm tractors.

### 3.2.5 – ISO 11446 13-pin plug

- The Trailer is fitted with an ISO11446 13-pin plug.
- If your towing vehicle is fitted with a single 7pin socket (12N), a 13/7-pin adaptor is available from your local Ifor Williams distributor. However please note that in this case the trailer reversing lights will not be powered from the towing vehicle.
- Be aware that some towing vehicle manufacturers supply their 13-pin sockets with only 7 or 8 powered pins. As is the case with the 7-pin socket above, the trailer reversing lights will not be powered. Please contact your local towing vehicle dealer for advice on how to upgrade your 13-pin socket to enable these functionalities.
- If your towing vehicle has twin 7-pin sockets (12N & 12S) an adaptor can be purchased to fully convert your 13-pin plug for use with your towing vehicle.

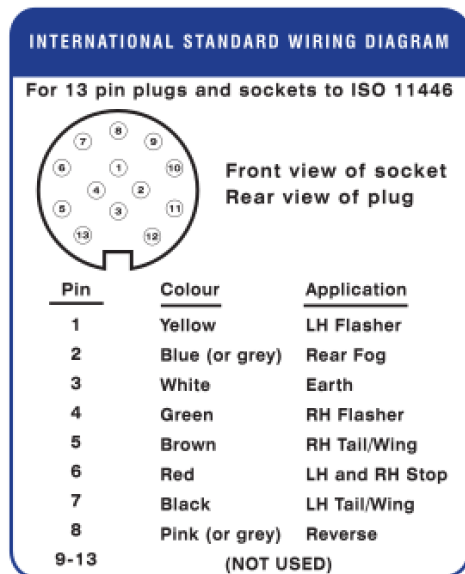

## **3.3 – Coupling**

### **3.3.1 – Coupling components**

#### **Coupling Drawbar & Jockey Wheel:**

1. Drawbar
2. Overrun unit (Coupling body)
3. Coupling head/Eye
4. Handbrake lever
5. Breakaway cable & clip
6. Lighting cable & Plug
7. Jockey wheel operating handle
8. Jockey wheel 'R' Clip

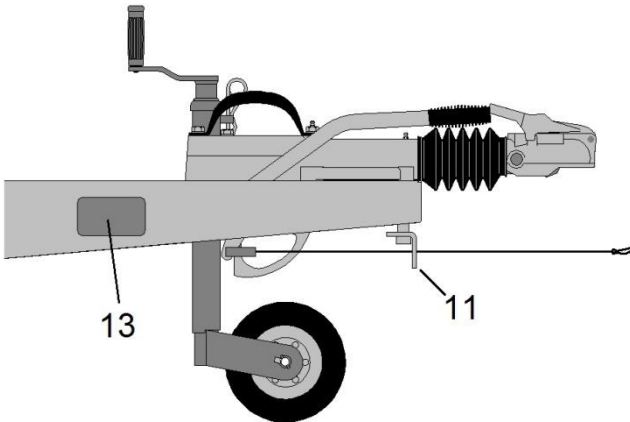
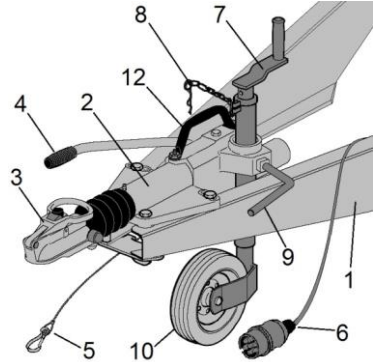

9. Jockey wheel clamp handle
10. Jockey wheel
11. Breakaway cable guide

- 12. Manoeuvring handle
- 13. Manufacturers type plate

### Coupling head

- 14. Release button (N/A on eye type)
- 15. Operating handle (N/A on eye type)
- 16. Lock & cover (N/A on eye type)
- 17. Wear indicator tab (N/A on eye type)

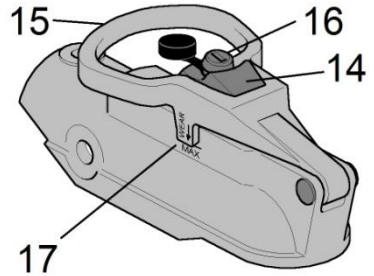

### 3.3.2 – Pre-Coupling Checks

- Check the condition of the breakaway cable. If frayed or kinked, replace before using trailer.
- Check that the ball is clean, and the coupling head cup is well greased.
- Note the position of the Coupling wear indicator relative to the “MAX” mark on the Coupling Head body. (This will be compared with the position of the indicator after coupling and will indicate whether the tow ball is worn (see section 5.3.4 below)

### 3.3.3 – Attaching the Trailer to the Towing Vehicle

- Ensure that the trailer handbrake is fully applied.
- Disengage the jockey wheel R clip.
- Ensure that the jockey wheel clamp handle is tight and, by turning the jockey wheel jack handle, raise the coupling to a height greater than that of the coupling ball.
- (Never attempt to lift the front of the trailer onto the coupling manually. Always use the jockey wheel.)
- Reverse the towing vehicle up to the trailer so that the coupling head is directly over the towing ball. Fully apply the towing vehicle handbrake and stop the engine.



When reversing your vehicle towards the trailer, if available, use an assistant to direct you and take great care to avoid striking the coupling head which could cause damage to towing vehicle and trailer coupling. The assistant should stand where the driver can see them and not where they can be crushed between towing vehicle and trailer or simply knocked over by the towing vehicle.

- Remove the protective cap and unlock the coupling head (turn the key anti-clockwise).
- With the tow-ball correctly positioned below the trailer coupling apply the vehicle handbrake and then press the release button on the coupling head THEN lift the handle. While continuing to hold the handle up, lower the coupling head by means of the jockey wheel jack handle until the coupling head is in place over the towing vehicle ball, then release the handle.
- If the handle has not been raised sufficiently or not been raised before the trailer was lowered onto the ball, the coupling can “sit on” the ball – giving the appearance of being coupled. Test that the ball is engaged by attempting to lift the coupling off the ball with the jockey wheel.

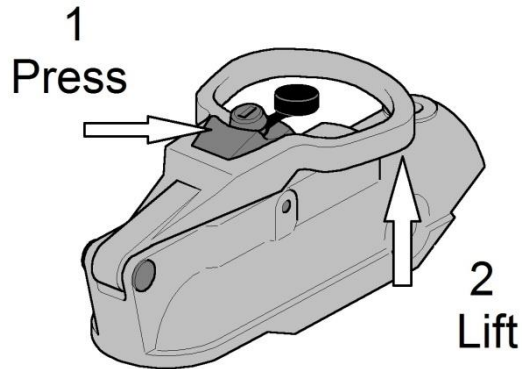

- With the coupling head correctly engaged on the tow ball, check that the coupling wear indicator is further away from the “MAX” point than noted in section 5.3.4. If it is not then the tow ball is excessively worn and should be replaced. Consult your local IWT Distributor

- Retract the jockey wheel until it is fully wound up.
- Line up the anti-rotation pin on the jockey forks with the notch on the stem and wind the wheel further up so it can no longer rotate.
- Hold the top of the jockey wheel assembly and release the clamp.
- Taking care lift the jockey assembly fully up, position the wheel well clear of the brake linkage and inside the drawbar channel with the wheel trailing rearwards.
- Clamp the jockey wheel in place.
- Turn the jockey wheel handle the small amount necessary to make the small U-shaped brackets on the handle and the body align, then engage the jockey wheel R clip to prevent lowering in transit. This is most important.
- Attach the breakaway cable to the attachment eye or strong point of the towing bracket, either directly to a dedicated loop or eye.

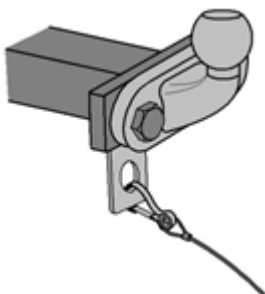
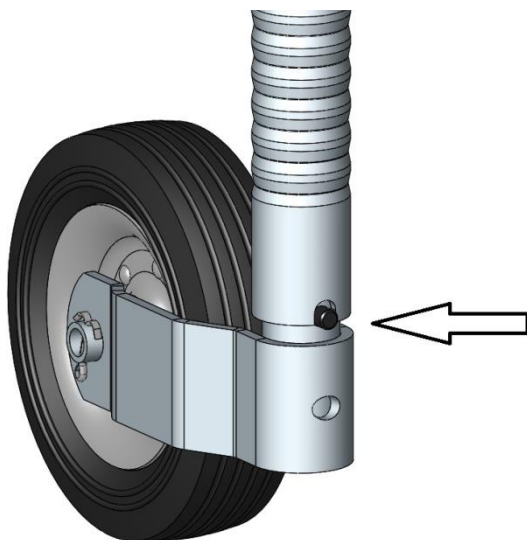

- Attach the electrical plug to the towing vehicle's socket ensuring there is enough slack in the cable for the trailer to allow tight turns, without the cable dragging on the road.
- Release the trailer handbrake.

### **3.3.4 – Final Checks Before Moving Off**

- Check that all the lights are operating correctly.
- Check the trailer has the same registration plate as the towing vehicle
- Check the breakaway cable cannot drag along the ground or become taut during normal use.

## **3.4 – Driving Safely**

### **3.4.1 – Driving Licence**

Check that your driving licence permits you to tow this vehicle / trailer combination. (See booklet Towing and the Law.)

### **3.4.2 – Towing Speed**

- The national maximum speed limit when towing is 60 mph.
- NOTE: The 60mph limit is allowed on motorways and dual carriageways with a central crash barrier only. On other unrestricted roads the national limit is 50mph.
- There is no guarantee that every vehicle trailer combination, loaded with every load the trailer might carry, in every weather condition is capable of being towed safely at the maximum legal speed. Proceed with caution and build confidence in towing stability slowly.

### 3.4.3 – Towing Stability

All our trailer models are of a well-balanced design and should be safe to tow. The common causes of poor stability include:

- Imposed load (trailer to towing vehicle) too low. Aim for minimum 4% of GTW imposed on towing vehicle but do not exceed the permitted maximum for the towing vehicle.
- Trailer not level when loaded, sloping down towards the front with the inevitable result that the trailer front axle load is more highly loaded than the rear axle. Slightly higher towards the front (slightly more load on the rear axle) is acceptable. Correction involves raising the vehicle coupling or (if coupling spacers are fitted) lowering the trailer coupling. Moving the load backwards or forwards to get the desired coupling height is not a solution, it will result in an incorrect coupling imposed load.
- Towing vehicle tyre pressures too low. Set them at the maximum recommended by the vehicle manufacturer
- Trailer tyre pressures below specified value will lower trailer stability.
- A high load or a moving load (animals and to a lesser extent transported vehicles). The existence of national speed limits is no guarantee that any load can be towed safely at that speed. In both these cases it may be necessary to limit maximum speed to a figure well below the national limits to maintain an adequate margin of stability – see snaking below.

### 3.4.4 – Snaking

This is a term used to denote an unstable towing vehicle and trailer combination where the trailer 'weaves' from side to side often causing or caused by a similar swaying movement in the towing vehicle itself.

#### **Causes:**

- Everything listed under Towing Stability above.
- Excessive speed, especially downhill or a flat-fronted trailer behind a low towing vehicle.

- Side winds.
- Overtaking – when the “bow wave” off the vehicle being overtaken hits the trailer
- Being overtaken by a large fast-moving vehicle – again bow wave effect as above
- Erratic driving – smooth steering inputs and concentration on steering a steady course are particularly important when towing. Snaking often starts at the steering wheel.



### **The correct reaction to snaking is vital – be prepared**

If you do find your outfit snaking, try to keep the steering wheel in as central position as possible, decelerate and avoid braking if possible.

## **3.5 – Parking and detaching the trailer**

### **3.5.1 - Parking the Trailer**

Choose the area where the trailer is to be parked with care. Ideally the trailer should be parked on firm level ground to safeguard against the trailer rolling or sinking into the ground. Always chock the wheels as well as applying the handbrake on sloping ground.

### **3.5.2 - Detaching the Trailer**

- When you have manoeuvred the trailer into its parking position apply the towing vehicle handbrake and switch its engine off.
- Apply the trailer handbrake.
- If the trailer is on sloping or uneven ground then securely chock the road wheels.
- If the trailer was reversed into position or is pointing downhill it is likely that the drawtube is compressed. This will make uncoupling difficult so it is advisable to move the towing vehicle

forwards a small amount, after the trailer handbrake has been applied, so as to extend the drawtube.

- Detach the trailer's lighting cable from the towing vehicle's socket and place it into the parking socket provided on the trailer coupling.
- Release the jockey wheel clamp, lower the jockey wheel to the ground and retighten the clamp securely.
- Remove the R-clip and turn the jockey wheel handle two turns to start lifting the imposed load off the coupling.
- As shown in the illustration in section 3.3.3, press the release button and then lift the handle. Keep the handle in the lifted position with one hand and simultaneously wind the jockey wheel up with the other hand until the coupling is clear of the tow ball.
- Release the safety cable. (Most safety cables are broken because this step is missed.)
- Drive the towing vehicle clear.
- It is advisable to fit a tow-ball cover to the vehicle tow-ball immediately. Failure to do so will likely result with grease from the vehicle tow-ball getting on to clothing.

## 4 Maintenance

### 4.1 – General

It is recommended that you have your trailer serviced and/or repaired by an authorised Ifor Williams Distributor. Maintenance is the responsibility of the owner/operator and should be carried out according to the schedules below.

Frequency	Part	Check For	Action
Before every journey	Wheel bolts	Correct torque	110 Nm (81 lbf.ft) for 5-stud wheels. 88 Nm (65 lbf.ft) for 4-stud wheels.
Before every journey	Lights	Check function	Rectify if necessary

Before every journey	Tyres	Correct pressure	Inflate to recommended (cold) pressures
Before every journey	Tyres	Cuts or damage – especially outer sidewalls	Consult tyre Distributor if any damage found.
Before every journey	Coupling head	Before and after wear indicator readings as described in section 5.3.4	Consult local distributor
Before every journey	Coupling Bellows	Splits	(Consult local distributor)
Before every journey	Coupling head and tow ball	Adequate grease	Add LMP grease as necessary
Before every journey	Breakaway cable	Kinks, frayed wire or other damage	Consult local distributor
Every 1000 miles or 2 months whichever is sooner	Brake Adjustment	(Assume adjustment is required)	Consult local distributor
Every 1000 miles or 2 months whichever is sooner	Brake Cables	Check condition	Consult local distributor
After first laden journey and then every 1000 miles or 2 months whichever is sooner	U-bolts	Check torque	Apply 140 Nm (103 lbf.ft) to every U-bolt nut. [Note: 18mm A/F socket required.]
Every 1000 miles or 2 months whichever is sooner	Bump stops	Check all bump stops are in place and undamaged	Consult local distributor
Every 1000 miles or 2 months whichever is sooner	Spring eye bushes	Check for wear	Consult local distributor
Every 1000 miles or 2 months whichever is sooner	Coupling	Check condition and amount of grease	Grease via grease nipples on top of body
Every 3000 miles or 6 months whichever is sooner	Brake Linings	Check lining wear	If less than 1.5mm of lining thickness remains, consult local distributor

Every 3000 miles or 6 months whichever is sooner	Coupling Damper	Carry out Drawtube reaction test described in section 5.3.3	Consult distributor	local
--	-----------------	---	---------------------	-------

## 4.2 - Parts

### 4.2.1 Replacement parts

A comprehensive list of all approved replacement parts specific to your trailer can be found in the Ifor Williams Trailers Parts catalogue. The latest version can be found at [www.iwt.no](http://www.iwt.no) or copies are available from your local distributor.

### 4.2.2 Accessories

A comprehensive list of approved accessories specific to your trailer can be found in the Ifor Williams Trailers Parts catalogue.

Examples of available accessories can also be found in the relevant trailer model brochures.

The latest versions of these can be found at [www.iwt.no](http://www.iwt.no), or copies are available from your local distributor.

## 5 Trailer Running Gear Maintenance

**These procedures must be carried out by competent persons. If you have any doubts about your ability to complete any of the procedures we recommend these tasks are performed by your local distributor.**

### 5.1 Tyres

Tyres must be maintained at the pressure indicated on the multifunction sticker located on the trailer. Under-inflation will adversely affect

handling and fuel consumption and will lead to premature wear. If seriously under-inflated, a tyre will overheat and fail very rapidly.

When renewing tyres, always ensure that you purchase a tyre of the same size and load/speed index rating. This will be found on the sidewall of the tyre. E.g. 165/60R13C 96/94N. Different makes or models of tyres of the same size can have widely differing load/speed index ratings and inflation pressures. Use of a tyre with a lower rating can be dangerous. If in doubt, ask a tyre distributor or our Customer Care department.

### **DO NOT REPLACE WITH LOWER RATED TYRES**



The maximum gross weight figure given on the trailer plate is always equal to or less than the approved maximum load for the tyres multiplied by the number of tyres on the trailer. In some cases, this includes a bonus load which is allowed for trailer use up to 60 mph. Other maximum load figures are marked on some tyres. These do not apply to the UK or Europe and should be disregarded.

## **5.1.1 Tyre Repairs**

Punctures should be inspected and repaired by a specialist tyre distributor. Do not fit tubes to tubeless tyres as this can lead to a “blow out” in the event of a further puncture. If the tyre is too severely damaged for a repair to be carried out the tyre should be replaced

## **5.2.1 Jacking up the Trailer**



### **Don'ts:**

- Don't place the jack on the centre line of the trailer under axles or chassis cross members.
- Don't place the jack directly under the bodywork edges, mudguards and front & rear bumpers.
- Don't place the jack under the suspension springs.
- Don't place the jack under the drawbars.

## 5.2.2 Jacking Points

1. Outer ends of the axles.
2. Outer ends of the chassis cross members beside the chassis rails.

## 5.2.3 Fitting Wheels

- Ensure wheel bolt threads and wheel seating surfaces are clean and dry – DO NOT LUBRICATE BOLTS.
- Place wheel over locating rim on the hub.



- Tighten each bolt slightly and then tighten to the torque figure given below, following the sequence shown in the diagram to the right.

Bolt size: 4 x M12

Torque: 65 lb ft., 88 Nm, 9 kgm

Socket size: 19mm A/F

Bolt size: 5 x M14

Torque: 81 lb ft., 110 Nm, 11 kgm

Socket size: 19mm A/F

**Wheel bolts should be checked after the first 25 miles of service and subsequently before every journey.**



## 5.2.4 Spare Wheel

This is of the same type as the wheel/tyres fitted to the trailer and is secured in place using two of the standard wheel bolts. These bolts should be fitted opposite to each other, e.g. Position 1&2, 3&4, etc.

## 5.3 Brakes and Coupling

Your trailer is fitted with Knott brakes and coupling. The Knott brakes are fitted to IWT axles and within IWT own brake drums. Supplied within the user manual pack is a Knott Maintenance & Servicing information leaflet which covers the following maintenance procedures:

- Replacing brake assembly complete
- Replacing brake shoes
- Brake adjustment
- Replacing brake cable (Bowden cable)
- Replacing breakaway cable
- Replacing coupling head & bellow
- Replacing the coupling damper

**These procedures must be carried out by competent persons. If you have any doubts about your ability to complete any of the procedures we recommend these tasks are performed by your local distributor.**

Brake drum removal and replacement requires the axle nut to be removed and refitted. A new axle end nut must be fitted every alternate time it is removed and refitted. Tighten to a torque of 350Nm/260ft lb and lock into one side of the stub axle groove as shown below:

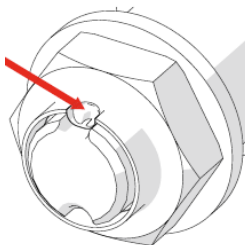

### 5.3.1 Brake Service Intervals

- Brake adjustment should be checked after the first 100 miles and subsequently every 1000 miles or 2 months (whichever is the sooner).
- Brake lining conditions should be checked every 3000 miles or 6 months.

**This can be carried out as follows without removing the brake drum:**

Remove the two plastic bungs from the rear of each brake and visually check the thickness of the lining, replacing the bungs after checking. If the thickness is less than 1.5mm the linings should be replaced.

- Brake cables. To ensure smooth operation of the brakes and to reduce the possibility of premature brake wear, it is recommended that the brake cables are replaced every 6000 miles or 12 months (whichever is the sooner) at the same time as the brakes are checked.
- Brake linkage. All moving parts should be greased or oiled monthly.

### 5.3.2 Coupling Unit Service Intervals

- The general condition of the overrun coupling unit should be checked monthly.
- To minimize wear on your towing ball and coupling head, clean out the cup in the coupling head monthly and apply new grease.

Service as follows every 3000 miles or 6 months, whichever is sooner:

- Thoroughly examine all moving parts for wear and correct functioning.
- Grease the drawtube bearings by means of the grease nipples.
- Clean and grease bearing parts and pivot pins.
- Ensure correct functioning of all pivot pins and levers and oil monthly.

### 5.3.3 Drawtube Reaction Test

Fully apply the handbrake lever. Push the coupling head as far back into the housing as possible. (It will move slowly under steady pressure.) On release, the coupling head should slide gradually forward under the pressure of the gas-filled shock absorber. If it either fails to return to the forward position or returns immediately, contact your authorized distributor for advice.

### 5.3.4 Checking the Coupling Head for Excessive Wear

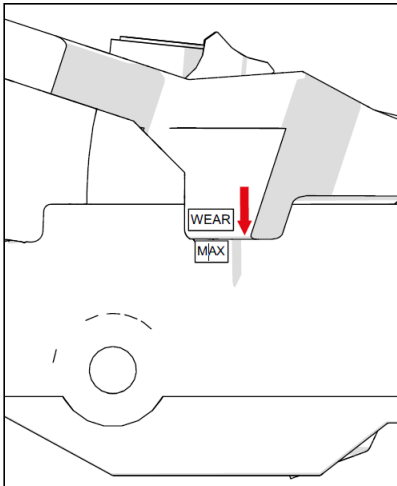

With the coupling disconnected from the tow ball, observe the position of the wear indicator lug relative to the "MAX" line. Then, with the coupling attached to the tow ball, re-check the position of the lug (see diagram). The gap between the base of the lug and the "MAX" line should be greater. If it is unchanged, excessive wear has taken place on the coupling head, the coupling ball, or both.

If this is the case, make a further check using a new 50mm ball.

If the gap is still unchanged the coupling head is excessively worn and should be replaced. However, if the gap is greater, your original 50mm ball should be replaced.

**Note:** If you need to replace your coupling head, carry out the check once more, as your tow ball may also need to be replaced. It is recommended that the coupling head and ball are replaced at the same time, as this will extend the service life of both components.

## **5.4 Jockey Wheel**

The jockey wheel should be checked monthly. Any damaged or worn parts should be replaced immediately. Lubricate the wheel spindle and screw thread every 6 months.

## **5.5 Leaf Springs**

Check the tightness of the self-locking nuts on the U bolts every 1000 miles or 2 months. Or at every brake service check, whichever is sooner. Tightening torque: 140 Nm. (Note – not rear spacer bolt tightening torque)

*We reserve the right to change and improve specifications without prior notice.*

*Whilst every effort has been made to ensure the accuracy of these instructions, they are intended only as a guide to the user.*

# Notes